

HydroLynx Systems, Inc.

**Model 50386P
Packaged Repeater**

Instruction Manual

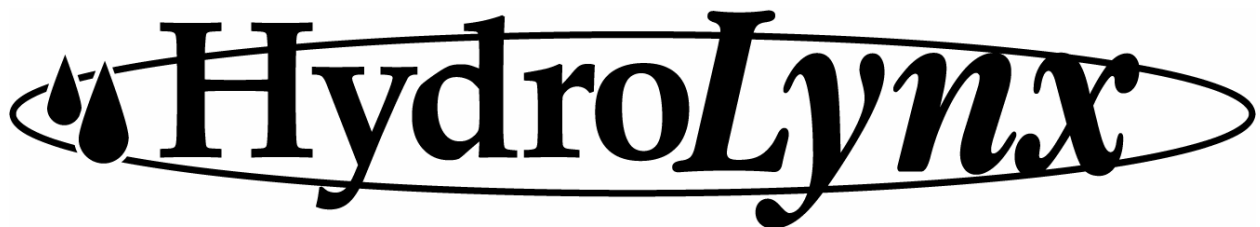

Document No: A102677
Document Revision Date: August, 2006

Receiving and Unpacking

Carefully unpack all components and compare to the packing list. Notify HydroLynx Systems immediately concerning any discrepancy. Inspect equipment to detect any damage that may have occurred during shipment. In the event of damage, any claim for loss must be filed immediately with the carrier by the consignee. If the equipment was shipped via Parcel Post or UPS, contact HydroLynx Systems for instructions.

Returns

If equipment is to be returned to the factory for any reason, call HydroLynx between 8:00 a.m. and 4:00 p.m. Pacific Time to request a Return Authorization Number (RA#). Include with the returned equipment a description of the problem and the name, address, and daytime phone number of the sender. Carefully pack the equipment to prevent damage during the return shipment. Call HydroLynx for packing instructions in the case of delicate or sensitive items. If packing facilities are not available, take the equipment to the nearest Post Office, UPS, or other freight service and obtain assistance with packaging. Please write the RA# on the outside of the box.

Warranty

HydroLynx Systems warrants that its products are free from defects in material and workmanship under normal use and service for a period of one year from the date of shipment from the factory. HydroLynx Systems' obligations under this warranty are limited to, at HydroLynx's option: (i) replacing; or (ii) repairing; any product determined to be defective. In no case shall HydroLynx Systems' liability exceed product's original purchase price. This warranty does not apply to any equipment that has been repaired or altered, except by HydroLynx Systems, or that has been subjected to misuse, negligence, or accident. It is expressly agreed that this warranty will be in lieu of all warranties of fitness and in lieu of the warranty of merchantability.

Address

HydroLynx Systems, Inc.
950 Riverside Pkwy., Suite 10
West Sacramento, CA 95605
Phone: (916) 374-1800
Fax: (916) 374-1877
E-mail: hydro@hydrolynx.com

Copyright 8 2006 by HydroLynx Systems, Inc.

TABLE OF CONTENTS

SECTION NO.	PAGE NO.
Equipment Configuration and Parts Identification	4
1.0 INTRODUCTION	5
1.1 General Description	5
1.2 Equipment Included	5
1.3 Specifications	5
2.0 INSTALLATION	5
2.1 Site Selection	5
2.2 Assembly	6
2.2.1 Standpipe Hole	6
2.2.2 Antenna Mast	6
2.2.3 Solar Panel	6
2.2.4 Standpipe Installation	7
2.2.5 Placing Repeater	7
3.0 THEORY OF OPERATION	7
4.0 TESTING AND MAINTENANCE	7
4.1 Testing	7
4.2 Maintenance	7
5.0 FORMS AND DRAWINGS	8

Equipment Configuration and Parts Identification

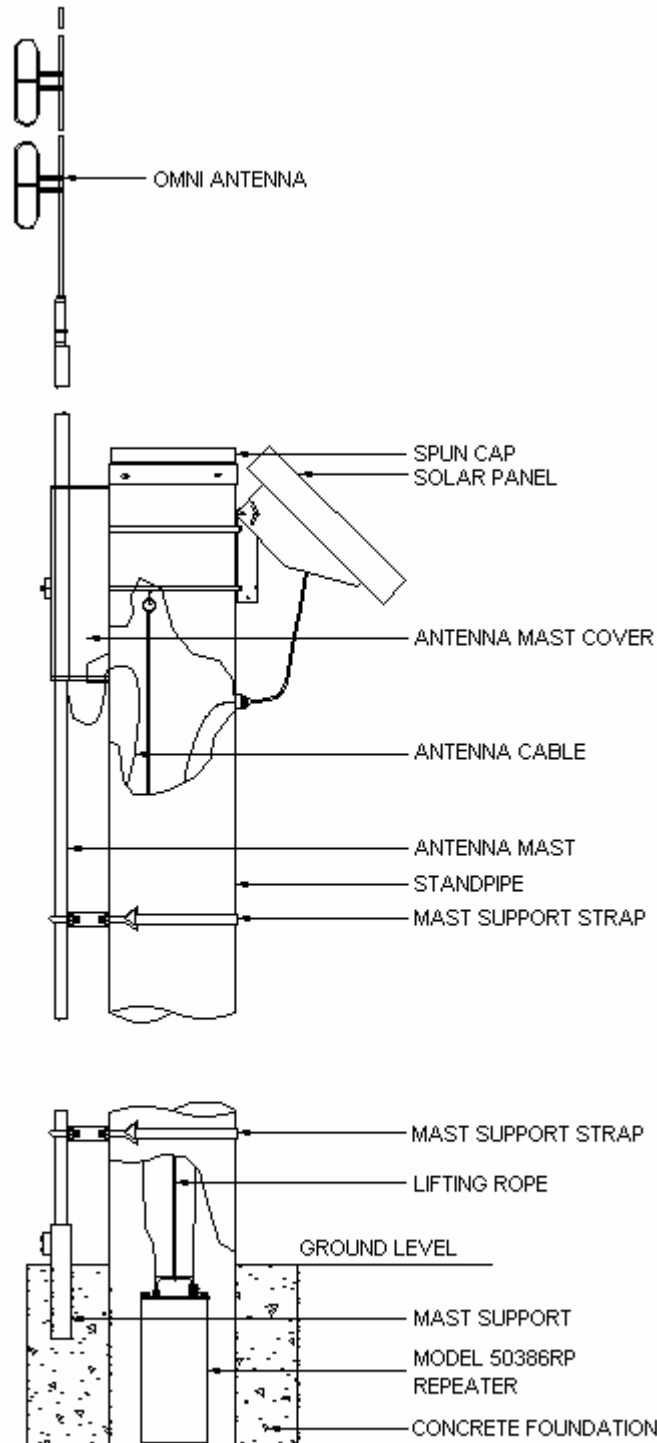

MODEL 50386P

1.0 INTRODUCTION

1.1 General Description

The 50386P Packaged Repeater includes a standpipe and an antenna mast assembly. The standpipe serves as weather proof housing for the ALERT data repeater and as the solar panel mounting platform. The antenna mast serves as the RF antenna tower. Packaged repeaters are used at locations where there is no existing radio tower.

1.2 Equipment Included

- 1> Standpipe
- 2> Standpipe Cap
- 3> Antenna Mast
- 4> Antenna Mast Cover
- 5> Antenna Mast Support Base
- 6> Antenna
- 7> Antenna Cable
- 8> 50386RP 50386 Repeater
- 9> Solar Panel
- 10> Lifting Rope
- 11> Access Door (optional)

1.3 Specifications

Height of mast: 21'

Material: Aluminum, stainless steel, galvanized steel

Standpipe: 16' standard height, other heights available

Antenna: DB224 VHF or DB408 UHF Omni

Repeater: Refer to 50386DCU manual

Solar panel: Refer to 5033 manual

2.0 INSTALLATION

Refer to Basic Gauge manual. Note: The mast assembly uses a support base that is set in concrete next to the standpipe.

2.1 Site Selection

To prevent radio path problems between remote sites and the central site, a line-of-sight radio path must exist between the repeater location and the remote and central sites. (Refer to Radio Path Survey).

Elevation is the foremost consideration when selecting a repeater location. The hills and mountains that create the radio path problem become the repeater location solution. Radio towers with multiple user access exist at many prime repeater locations.

Tall buildings are used in many urban settings as radio towers.

When the repeater shares a location with other radio equipment, the radio path survey must check for interference. The agency adding the equipment is responsible for correcting any interference problem unless it can be proven that another operator is non-compliant with FCC regulations and is therefore responsible for the interference.

2.2 Assembly

2.2.1 Standpipe Hole

Refer to Basic Gauge manual.

2.2.2 Antenna Mast

- \$ Slide mast enclosure over the mast.
- \$ Mount the antenna(s) to the mast with the hardware provided.
- \$ Route the antenna cable(s) through the hole(s) in the antenna mast enclosure and into the standpipe.
- \$ Adjust cable length for a four-inch drip loop and tighten the strain reliefs.
- \$ Attach the antenna mast enclosure to the standpipe with the hex-head screws provided.
- \$ Attach the mast support base to the antenna mast.

2.2.3 Solar Panel

- \$ Attach the solar panel to the standpipe using the mounting hardware provided. The solar panel clamps onto the 13" long, rotating bracket. Make certain that the clamps are firmly attached.
- \$ The rotating bracket fastens to the fixed bracket using four sets of bolts, nuts, and washers. This hardware is loosely attached at first.
- \$ The fixed bracket is attached onto the standpipe using stainless steel straps. Make certain that the panel is facing South before final securing of the mounting bolts and straps.
- \$ Adjust the rotating bracket for the appropriate solar angle. Refer to the solar panel manual for solar angle calculation information. Secure the four bolts of the rotating bracket at this point.
- \$ Route the cable through the strain relief in the wall of the standpipe.

2.2.4 Standpipe Installation

- \$ Place standpipe into hole and align.
- \$ Use rocks to stabilize.
- \$ Position mast support base and tighten bolts on antenna mast cover. This is not the final mast position. Leave space between mast and concrete level. See Figure 1.
- \$ Pour concrete.
- \$ Allow concrete to set.

2.2.5 Placing Repeater

- \$ Align antenna and mast into final position. Lower antenna mast into support until mast rests on concrete.
- \$ Connect the antenna and solar panel cables to the repeater.
- \$ Test repeater.
- \$ Lower repeater into standpipe.
- \$ Attach the standpipe cap with the hex-head screws provided.

3.0 THEORY OF OPERATION

The repeater receives data transmissions from remote sites and stores the data into its memory. It may then check for valid ID numbers. The repeater then re-transmits the data to the central site.

Refer to Basic Gauge and 50386DCU manuals for additional information.

4.0 TESTING AND MAINTENANCE

4.1 Testing

Refer to Basic Gauge manual for standard tests.

Note: A data transmission must be sent to the repeater to test the RF output.

4.2 Maintenance

Maintenance is critical to the continued performance of the repeater as well as to the longevity of the equipment and mounting hardware. Regularly scheduled maintenance should be performed using the basic gauge maintenance report form as a guide. Refer to the Basic Gauge manual for general system maintenance information. Refer to the

50386DCU manual for specific maintenance requirements. Maintenance forms are located in the appropriate manuals.

5.0 FORMS AND DRAWINGS

AC107553 5252P Assembly Drawing
AC108007 5033-3.0 Installation
AC108029 5252P Dual Freq. Outline
AC108030 5252P Single Freq. Outline

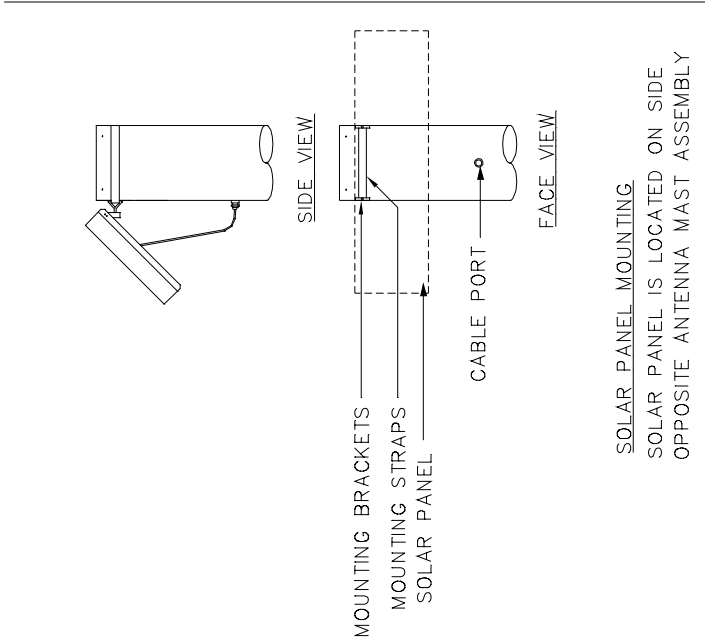

SOLAR PANEL MOUNTING
 SOLAR PANEL IS LOCATED ON SIDE
 OPPOSITE ANTENNA MAST ASSEMBLY

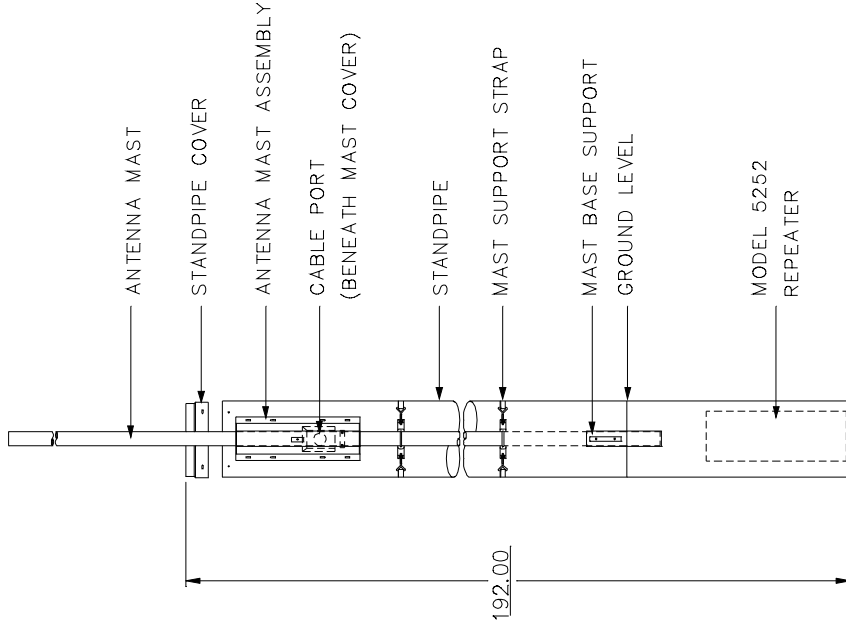

ECN#	DESCRIPTION	DATE
MODEL USAGE 5252P	HydroLynx	
MODEL NO. 5252P	TITLE REPEATER PACKAGE	
DRAWN BY S. HEINEMANN	DATE 1/22/99	REV B
CHECKED BY	SIZE ASSEMBLY	REV AC107553

NOTES: 1. REFER TO DRAWING NO. SP-1 FOR ASSEMBLY OF SOLAR-PANEL MOUNTING BRACKETS, AND REGULATOR PANEL.

FRONT VIEW

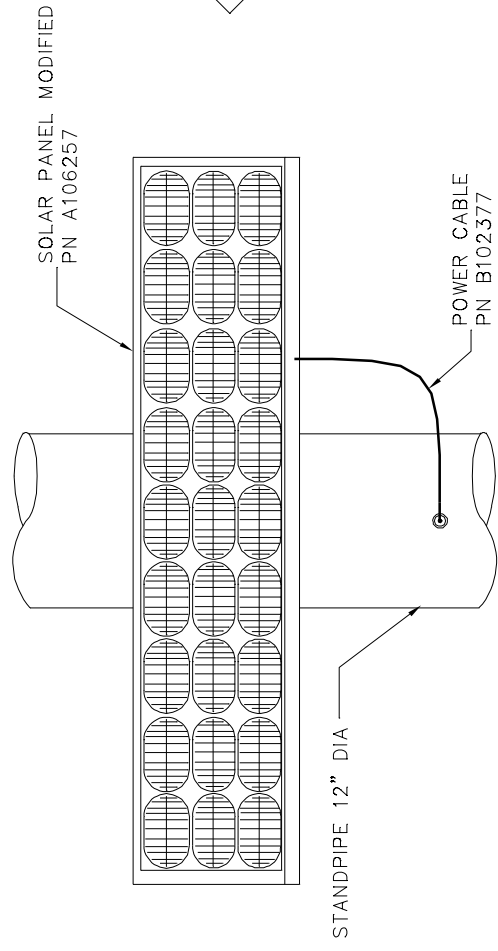

SIDE VIEW

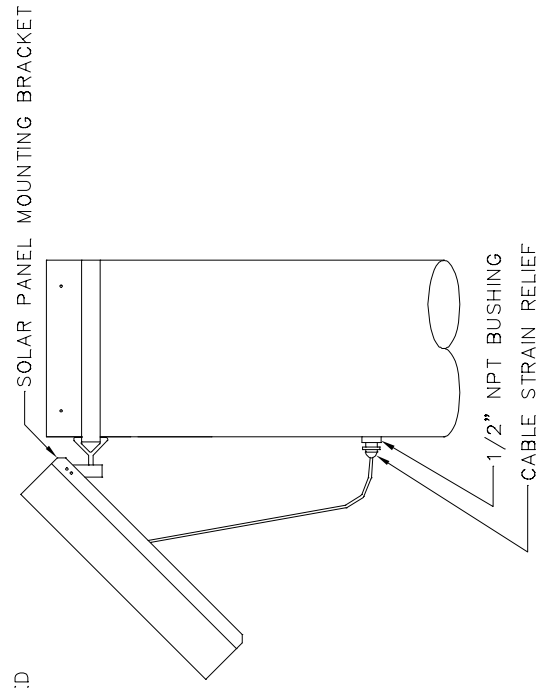

BOTTOM VIEW

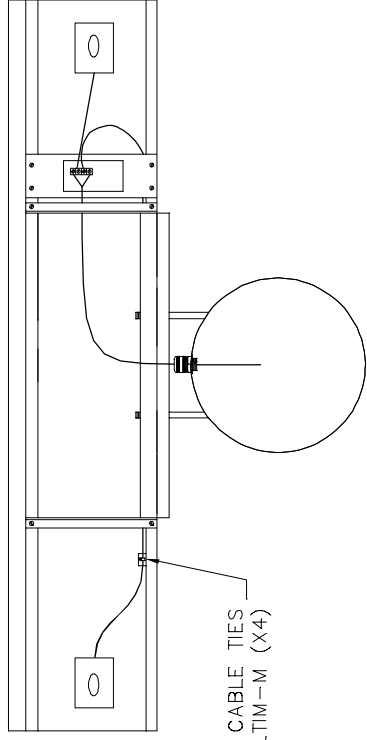

ECN#	DESCRIPTION	DATE
MODEL USAGE 5033-2.5	HydroLynx	
MODEL NO. 5033-3.0	TITLE SOLAR PANEL	
DATE 1/22/99	DWG TYPE MOUNTED ON STANDPIPE	
CHECKED BY S. HEINEMANN	DATE 1/22/99	SIZE B
	DWG NO. AC108007	REV

CABLE TIE MOUNT & CABLE TIES
TYPE 805-2003 (X4) & PLTIM-M (X4)

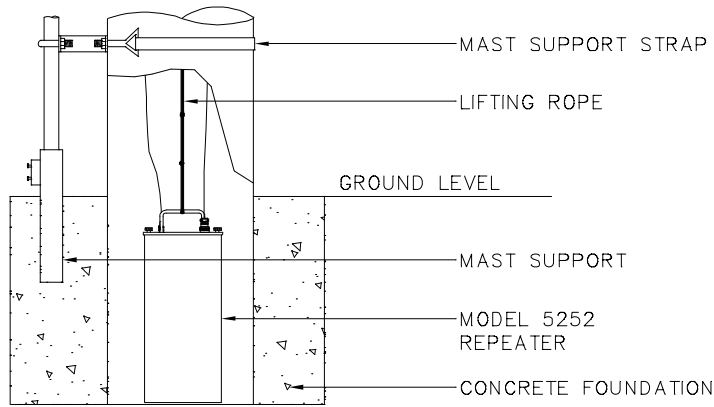
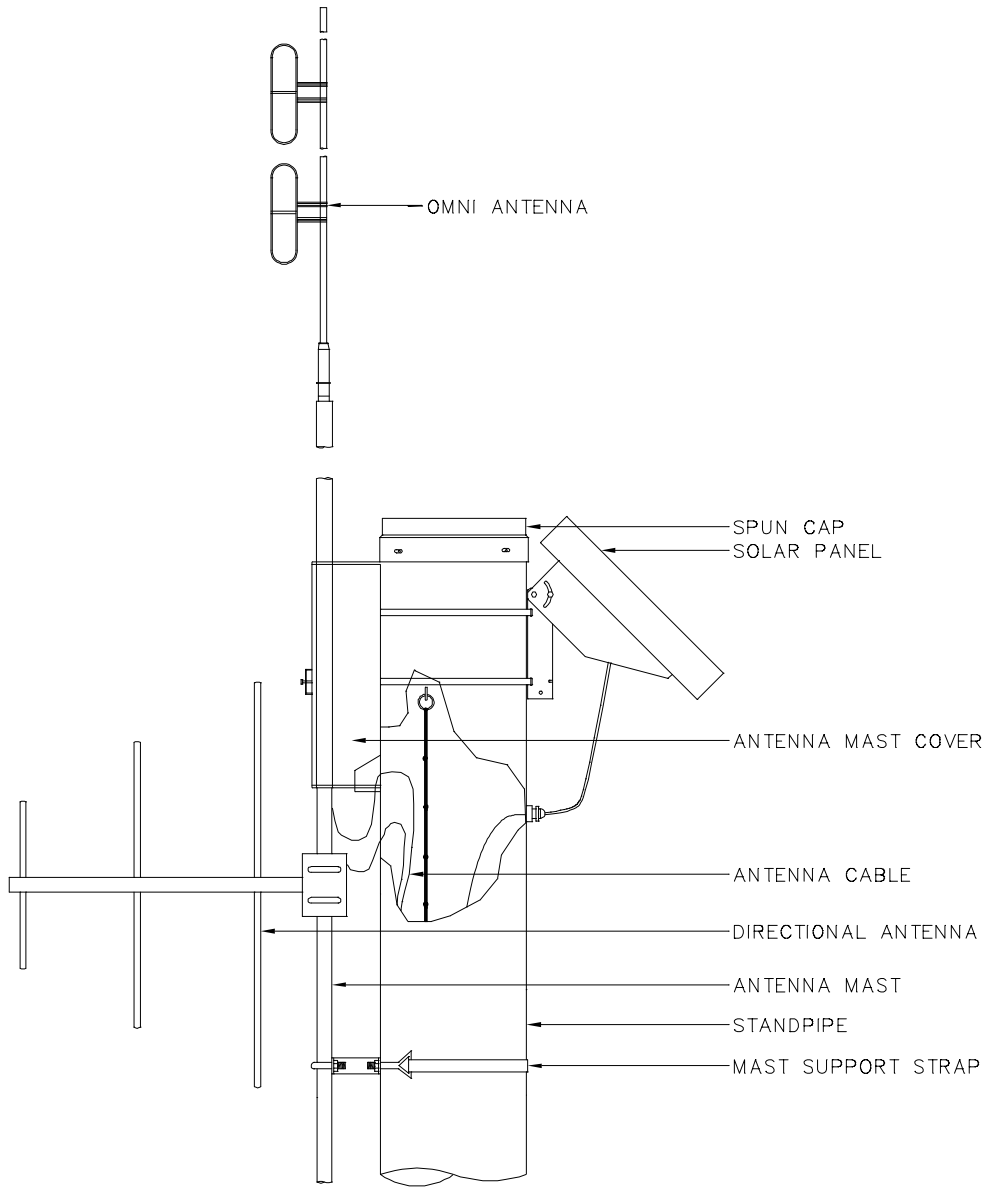

MODEL USAGE	
MODEL NO.	5252P-2
TITLE	REPEATER
DRAWN BY	M. MOORE
CHECKED BY	
DATE	8/25/99
DATE	
DWG TYPE	DUAL FREQUENCY
OUTLINE	
SIZE	B
DWG NO.	AC108029
REV	

HydroLynx

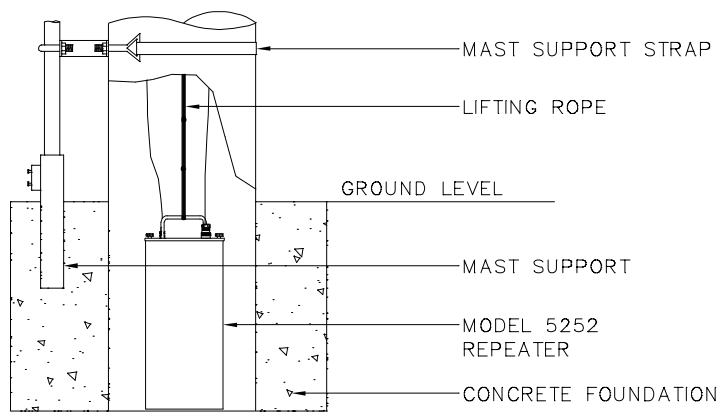
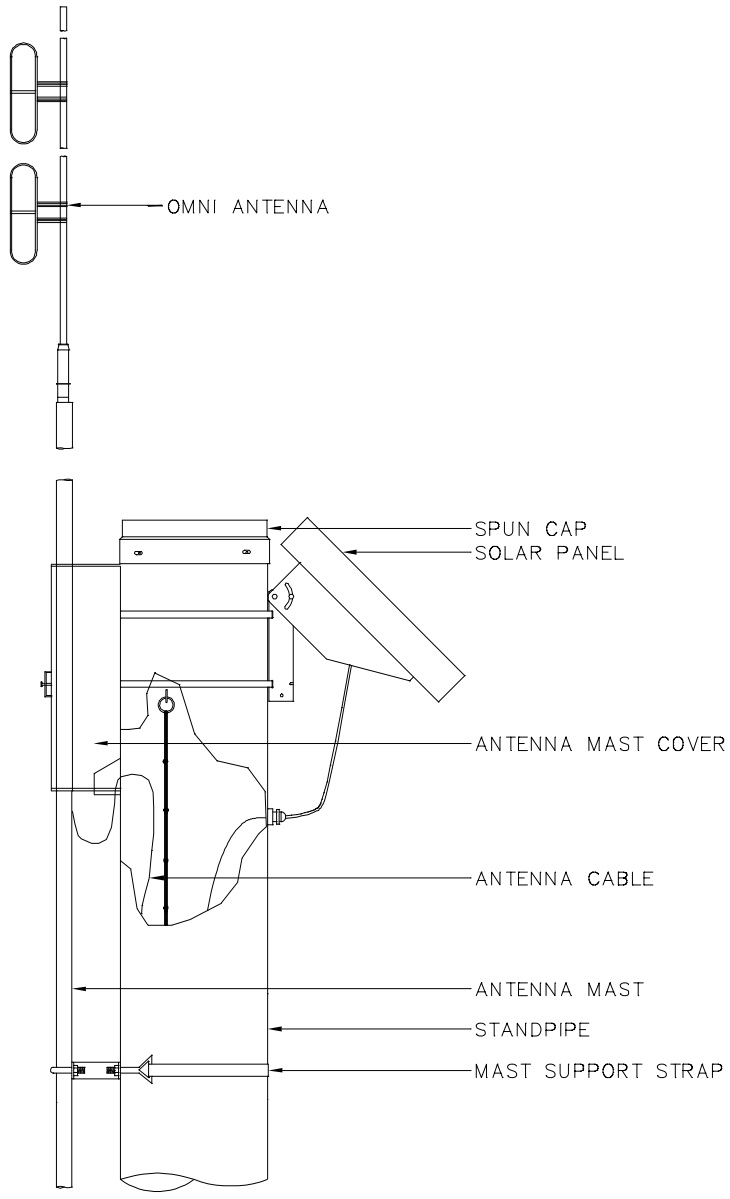

MODEL USAGE		HydroLynx	
MODEL NO.	5252P	REPEATER	
TITLE	SINGLE FREQUENCY OUTLINE		
DRAWN BY	M. MOORE	DATE	8/24/99
CHECKED BY		SIZE	B
		DWG NO.	AC108030
			REV